

DIFFERENTIAL LOW POWER TC & VCTCX0 MHz

SERIES „DTCVCTO“ 1.0–220 MHz

FEATURES

- + 100% pin-to-pin drop-in replacement to quartz and MEMS based XO
- + Ultra Performance Oscillator for Low Cost
- + TCXO function activated when Pin 1 is not connected
- + Excellent long time reliability—outperforms quartz-based XO
- + Excellent jitter performance
- + Very tight frequency stability as low as ± 2.5 ppm
- + Outstanding long term aging
- + Industry-standard packages: 3.2x2.5; 5.0x3.2; 7.0x5.0 mm
- + Pb-free, RoHS and REACH compliant / MSL1@260°C

APPLICATIONS

- + SATA, SAS, 10GB Ethernet, Fibre Channel, PCI-Express
- + Networking, broadband, instrumentation
- + Telecom
- + etc.

PARAMETER AND CONDITIONS	SYMBOL	MIN.	TYP.	MAX.	UNIT	CONDITION
LVPECL AND LVDS, COMMON ELECTRICAL CHARACTERISTICS						
Supply Voltage	V _{DD}	2.97	3.3	3.63	V	
		2.25	2.5	2.75	V	
		2.25	–	3.63	V	Termination schemes in Figures 1 and 2 - XX ordering code
Output Frequency Range	f	1	–	220	MHz	
Initial Tolerance	F _{init}	-2	–	2	PPM	At 25°C
Stability Over Temperature	F _{stab}	-2.5	–	+2.5	PPM	Over operating temperature range at rated nominal power supply voltage and load.
		-5	–	+5	ppm	
Supply Voltage	F _{VDD}	–	50	–	PPB	$\pm 10\%$ V _{DD} ($\pm 5\%$ for V _{DD} = 1.8V)
Output Load	F _{load}	–	0.1	–	PPM	15 pF $\pm 10\%$ of load
First Year Aging	F _{aging1}	-2	–	+2	PPM	25°C
10-year Aging	F _{aging10}	-5	–	+5	PPM	25°C
Operating Temperature Range	T _{use}	-40	–	+85	°C	Industrial
		-20	–	+70	°C	Extended Commercial
Storage Temperature Range	T _{stor}	-65	–	+150	°C	
Pull Range	PR		$\pm 12.5, \pm 25, \pm 50$		PPM	
Upper Control Voltage	VC _U	V _{DD} -0.1	–	–	V	All V _{DD} s. Voltage at which maximum deviation is guaranteed.
Control Voltage Range	VC _L	–	–	0,1	V	
Control Voltage Input Impedance	Z _{vc}	100	–	–	k Ω	
Frequency Change Polarity	–		Positive slope		–	
Control Voltage -3dB Bandwidth	V _{BW}	–	–	8	kHz	
Input Voltage High	VIH	70%	–	–	V _{DD}	Pin 1, OE or ST
Input Voltage Low	VIL	–	–	30%	V _{DD}	Pin 1, OE or ST
Input Pull-up Impedance	Z _{in}	–	100	250	k Ω	Pin 1, OE logic high or logic low, or ST logic high
		2	–	–	M Ω	Pin 1, ST logic low
Start-up Time	T _{start}	–	6	10	ms	Measured from the time V _{DD} reaches its rated minimum value.
Resume Time	T _{resume}	–	6	10	ms	In Standby mode, measured from the time ST pin crosses 50% threshold.
Duty Cycle	DC	45	–	55	%	Contact PETERMANN-TECHNIK for tighter duty cycle

GENERAL DATA (continued)

PARAMETER AND CONDITIONS	SYMBOL	MIN.	TYP.	MAX.	UNIT	CONDITION
LVPECL, DC AND AC CHARACTERISTICS						
Current Consumption	I _{DD}	–	61	69	mA	Excluding Load Termination Current, V _{DD} = 3.3V or 2.5V
OE Disable Supply Current	I _{OE}	–	–	35	mA	OE = Low
Output Disable Leakage Current	I _{leak}	–	–	1	µA	OE = Low
Standby Current	I _{std}	–	–	100	µA	ST = Low, for all V _{DDs}
Maximum Output Current	I _{driver}	–	–	30	mA	Maximum average current drawn from OUT+ or OUT-
Output High Voltage	V _{OH}	V _{DD} -1.1	–	V _{DD} -0.7	V	See Figure 1(a)
Output Low Voltage	V _{OL}	V _{DD} -1.9	–	V _{DD} -1.5	V	See Figure 1(a)
Output Differential Voltage Swing	V _{Swing}	1.2	1.6	2.0	V	See Figure 1(b)
Rise/Fall Time	T _r , T _f	–	300	500	ps	20% to 80%, see Figure 1(a)
OE Enable/Disable Time	T _{oe}	–	–	115	ns	f = 212.5 MHz - For other frequencies, T _{oe} = 100ns + 3 period
RMS Period Jitter	T _{jitt}	–	1.2	1.7	ps	f = 100 MHz, V _{DD} = 3.3V or 2.5V
		–	1.2	1.7	ps	f = 156.25 MHz, V _{DD} = 3.3V or 2.5V
		–	1.2	1.7	ps	f = 212.5 MHz, V _{DD} = 3.3V or 2.5V
RMS Phase Jitter (random)	T _{phj}	–	0.6	0.85	ps	f = 156.25 MHz, Integration bandwidth = 12 kHz to 20 MHz, all V _{DDs}
LVDS, DC AND AC CHARACTERISTICS						
Current Consumption	I _{DD}	–	47	55	mA	Excluding Load Termination Current, V _{DD} = 3.3V or 2.5V
OE Disable Supply Current	I _{OE}	–	–	35	mA	OE = Low
Differential Output Voltage	V _{OD}	250	350	450	mV	See Figure 2
Output Disable Leakage Current	I _{leak}	–	–	1	µA	OE = Low
Standby Current	I _{std}	–	–	100	µA	ST = Low, for all V _{DDs}
VOD Magnitude Change	ΔV _{OD}	–	–	50	mV	See Figure 2
Offset Voltage	V _{OS}	1.125	1.2	1.375	V	See Figure 2
VOS Magnitude Change	ΔV _{OS}	–	–	50	mV	See Figure 2
Rise/Fall Time	T _r , T _f	–	495	600	ps	20% to 80%, see Figure 2
OE Enable/Disable Time	T _{oe}	–	–	115	ns	f = 212.5 MHz - For other frequencies, T _{oe} = 100ns + 3 period
RMS Period Jitter	T _{jitt}	–	1.2	1.7	ps	f = 100 MHz, V _{DD} = 3.3V or 2.5V
		–	1.2	1.7	ps	f = 156.25 MHz, V _{DD} = 3.3V or 2.5V
		–	1.2	1.7	ps	f = 212.5 MHz, V _{DD} = 3.3V or 2.5V
RMS Phase Jitter (random)	T _{phj}	–	0.6	0.85	ps	f = 156.25 MHz, Integration bandwidth = 12 kHz to 20 MHz, all V _{DDs}
EXCELLENT RELIABILITY DATA						
MTBF						500 million hours
Shock Resistance:						10.000 g
Vibration Resistance:						70 g

PIN DESCRIPTION

PIN	SYMBOL		FUNCTIONALITY
1	VC	V control	Voltage control
	OE	Input	H or Open: specified frequency output L: output is high impedance
	ST	Input	H or Open: specified frequency output L: Device goes to sleep mode. Supply current reduces to
2	NC	NA	No Connect; Leave it floating or connect to GND for better heat dissipation
3	GND	Power	V _{DD} Power Supply Ground
4	OUT+	Output	Oscillator output
5	OUT-	Output	Complementary oscillator output
6	VDD	Power	Power supply voltage

TOP VIEW

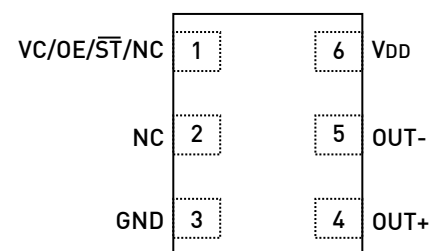

WAVE FORM DIAGRAMS

FIGURE 1(A). LVPECL VOLTAGE LEVELS PER DIFFERENTIAL PIN (OUT+/OUT-)

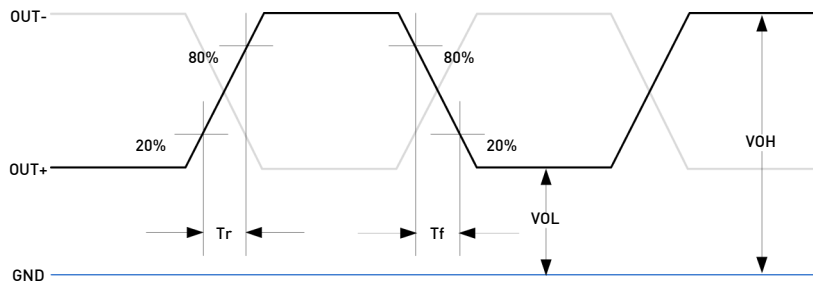

FIGURE 1(B). LVPECL VOLTAGE LEVELS ACROSS DIFFERENTIAL PAIR

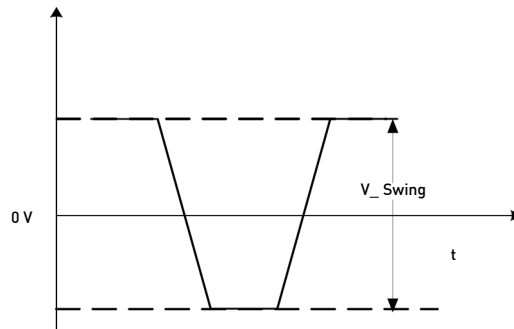
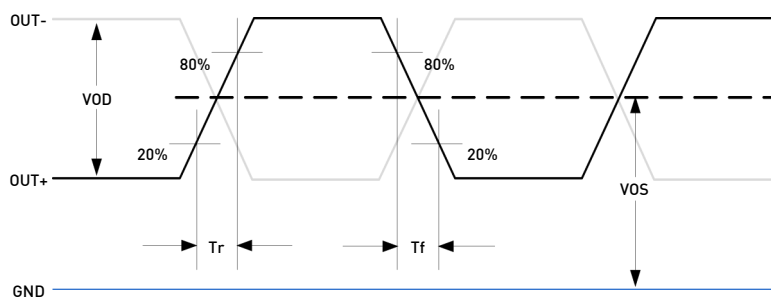

FIGURE 2. LVDS VOLTAGE LEVELS PER DIFFERENTIAL PIN (OUT+/OUT-)



TERMINATION DIAGRAMS

LVPECL:

FIGURE 3. LVPECL TYPICAL TERMINATION

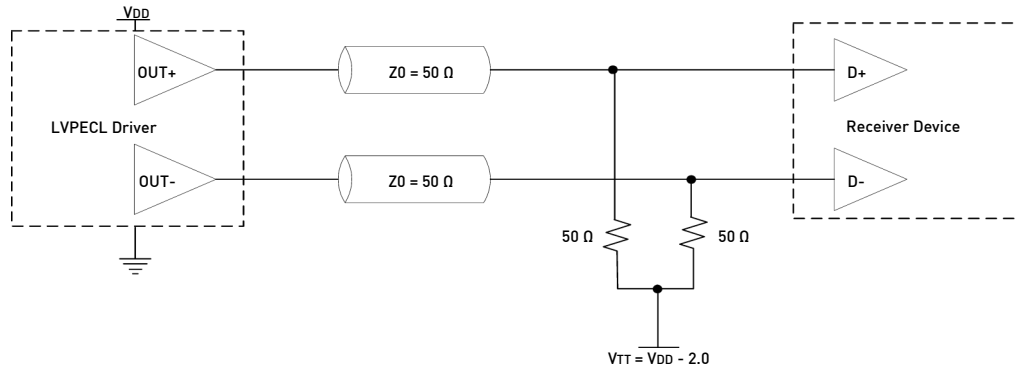

FIGURE 4. LVPECL AC COUPLED TERMINATION

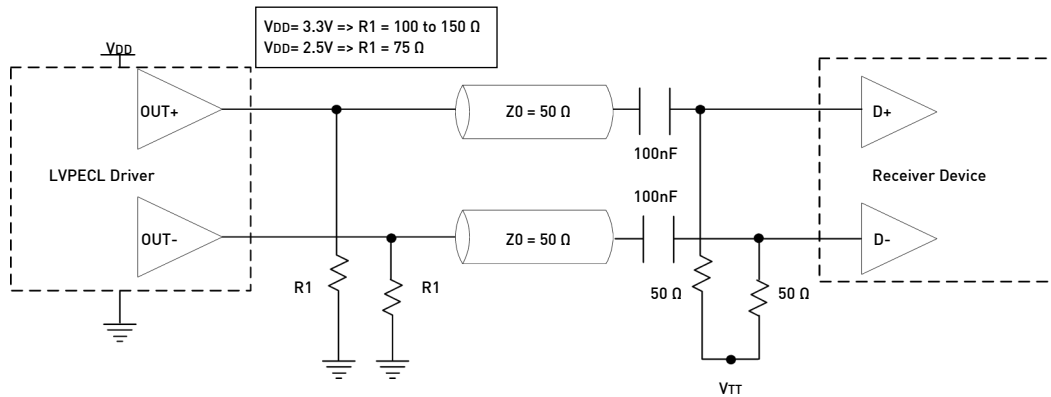
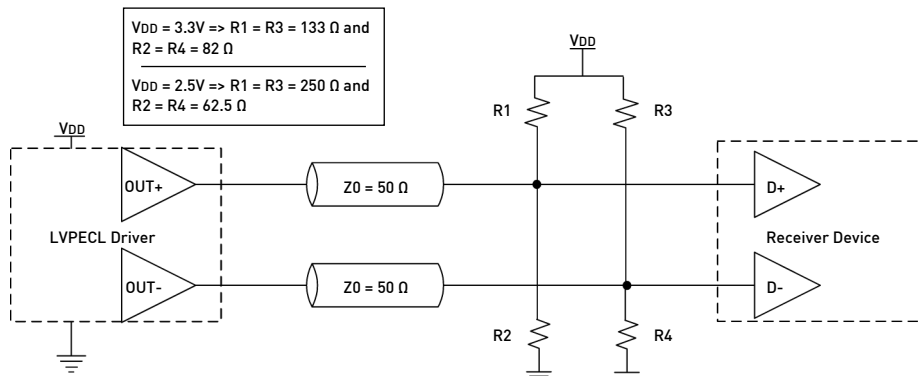

FIGURE 5. LVPECL WITH THEVENIN TYPICAL TERMINATION



TERMINATION DIAGRAMS

LVDS:

FIGURE 6. LVDS SINGLE TERMINATION (LOAD TERMINATED)

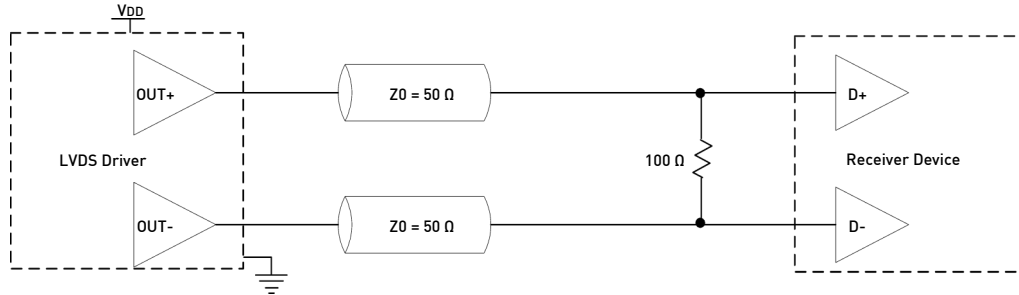

REFLOW SOLDER PROFILE

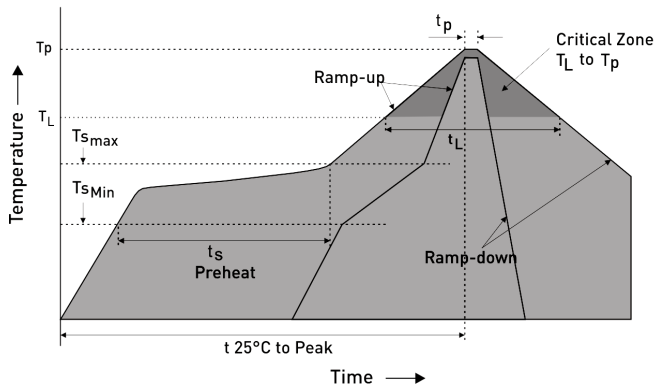

IPC/JEDEC Standard	IPC/JEDEC J-STD-020
Moisture Sensitivity Level	Level 1
TS MAX to TL (Ramp-up Rate)	3°C/second Maximum
Preheat	
- Temperature Minimum (TS MIN)	150°C
- Temperature Typical (TS TYP)	175°C
- Temperature Typical (TS MAX)	200°C
- Time (tS)	60 - 180 Seconds
Ramp-up Rate (TL to TP)	3°C/second Maximum
Time Maintained Above:	
- Temperature (TL)	217°C
- Time (TL)	60 - 150 Seconds
Peak Temperature (TP)	260°C Maximum
Target Peak Temperature (TP Target)	255°C
Time within 5°C of actual peak (tP)	20 - 40 Seconds
Max. Number of Reflow Cycles	3
Ramp-down Rate	6°C/second Maximum
Time 25°C to Peak Temperature (t)	8 minutes Maximum

DIMENSIONS AND PATTERNS

PACKAGE SIZE – DIMENSIONS (UNIT:MM)

3.2X 2.5 X 0.75 MM

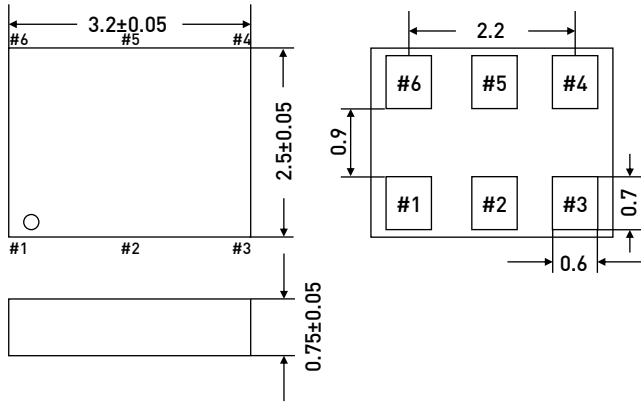

RECOMMENDED LAND PATTERN (UNIT:MM)^[1]

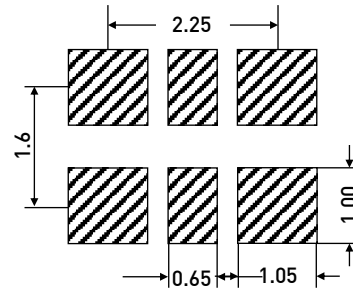

PACKAGE SIZE – DIMENSIONS (UNIT:MM)

5.0X 3.2 X 0.75 MM

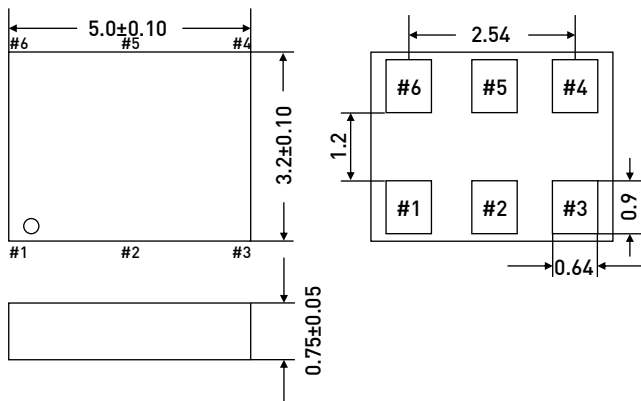

RECOMMENDED LAND PATTERN (UNIT:MM)^[1]

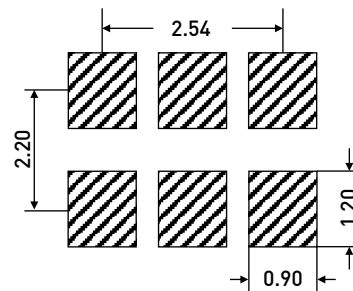

PACKAGE SIZE – DIMENSIONS (UNIT:MM)

7.0X 5.0 X 0.90 MM

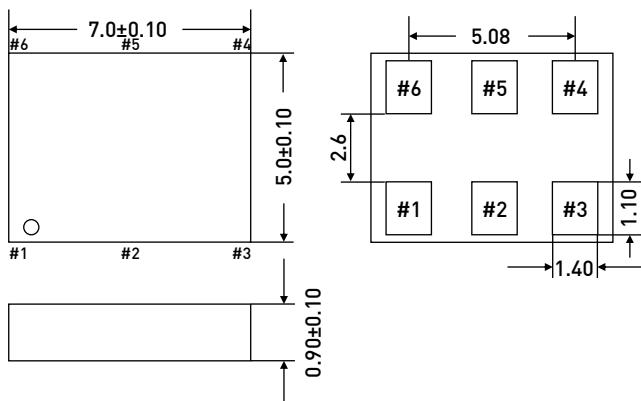

RECOMMENDED LAND PATTERN (UNIT:MM)^[1]

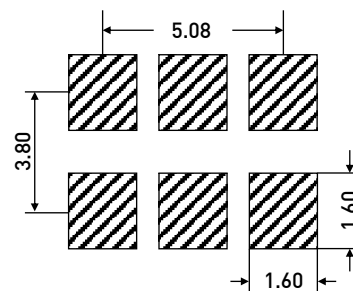

Note:

1. A capacitor value of 0.1 µF between VDD and GND is recommended.

ORDERING INFORMATION

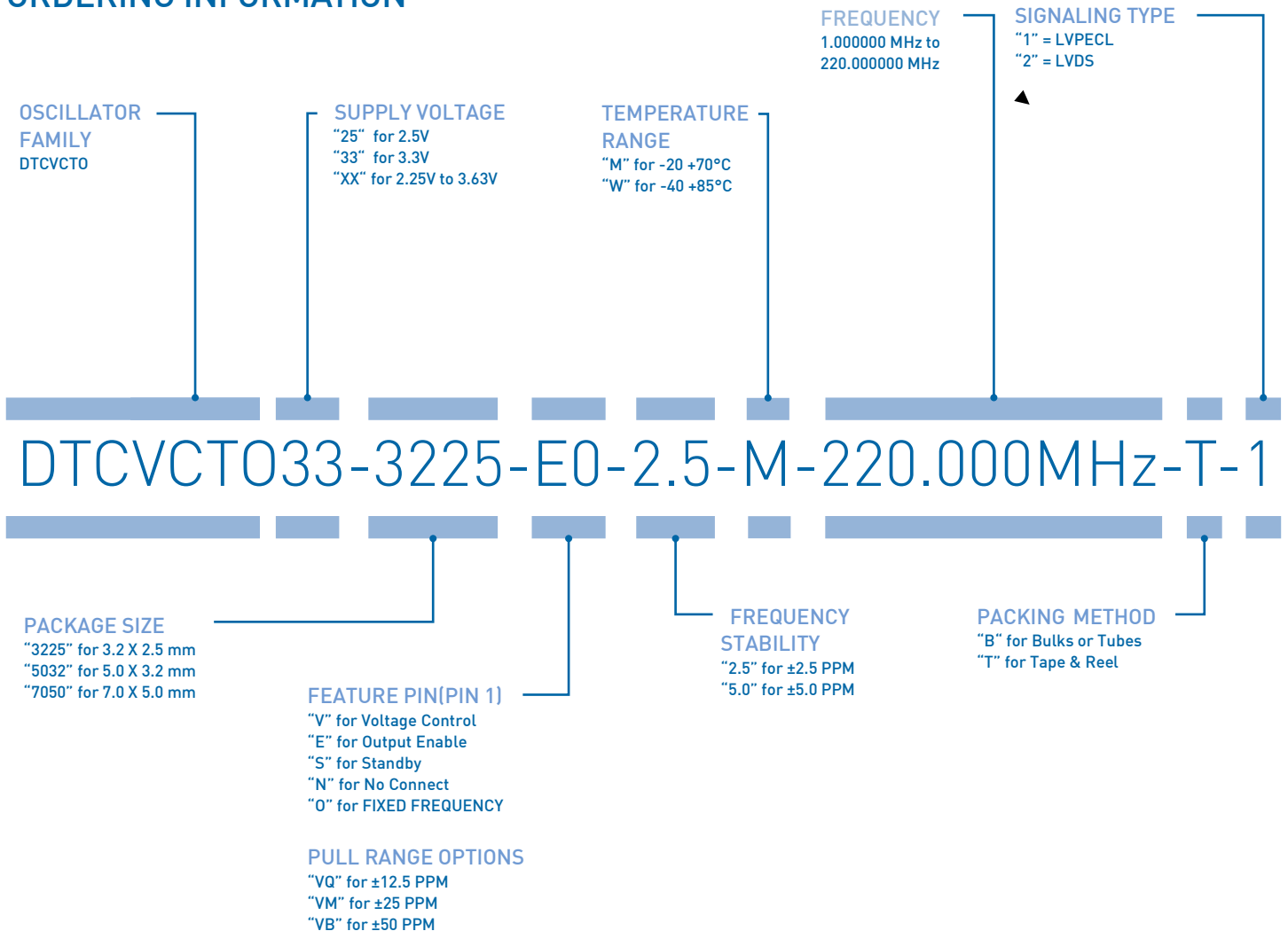

EXAMPLE: DTCVCT033-3225-E0-2.5-M-220.000MHz-T-1

[PLEASE CLICK HERE TO CREATE YOUR OWN ORDERING CODE](#)

SAMPLES ARE AVAILABLE WITHIN A SHORT DELIVERY PERIOD!



PREMIUM QUALITY BY PETERMANN-TECHNIK



OUR COMPANY IS CERTIFIED ACCORDING TO ISO 9001:2008 IN OCTOBER 2013 BY THE DMSZ CERTIFIKATION GMBH.

THIS IS FOR YOU TO ENSURE THAT THE PRINCIPLES OF QUALITY MANAGEMENT ARE FULLY IMPLEMENTED IN OUR QUALITY MANAGEMENT SYSTEM AND QUALITY CONTROL METHODS ALSO DOMINATE OUR QUALITY STANDARDS.